



Cambridge International Examinations
Cambridge International General Certificate of Secondary Education

GEOGRAPHY

0460/43

Paper 4 Alternative to Coursework

October/November 2015

INSERT

1 hour 30 minutes

READ THESE INSTRUCTIONS FIRST

The Insert contains Photograph A, Table 1 and Figs 2 and 3 for Question 1, and Tables 2 and 3 and Figs 5 and 9 for Question 2.

The Insert is **not** required by the Examiner.



The syllabus is approved for use in England, Wales and Northern Ireland as a Cambridge International Level 1/Level 2 Certificate.

This document consists of **7** printed pages and **1** blank page.

Photograph A for Question 1



Fig. 2 for Question 1

Measuring equipment

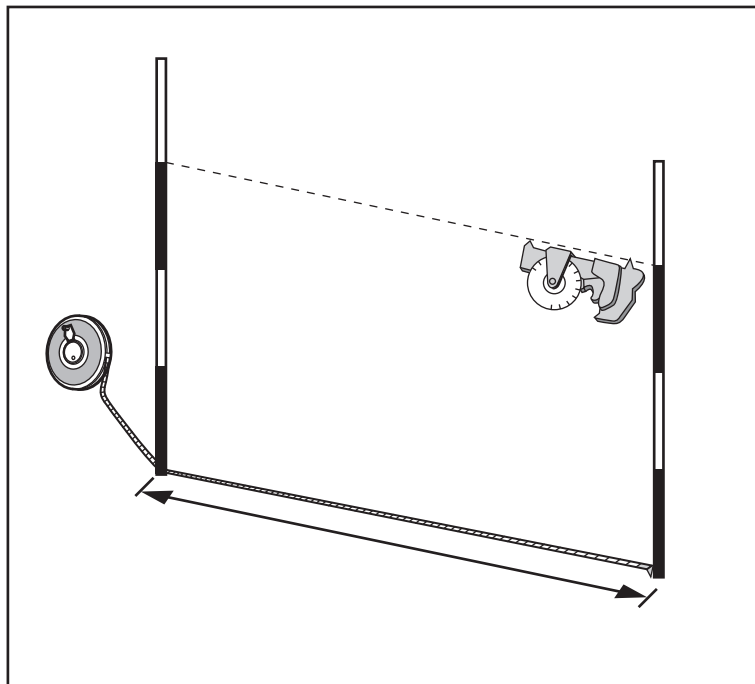

Fig. 3 for Question 1

Transect profile across sand dunes

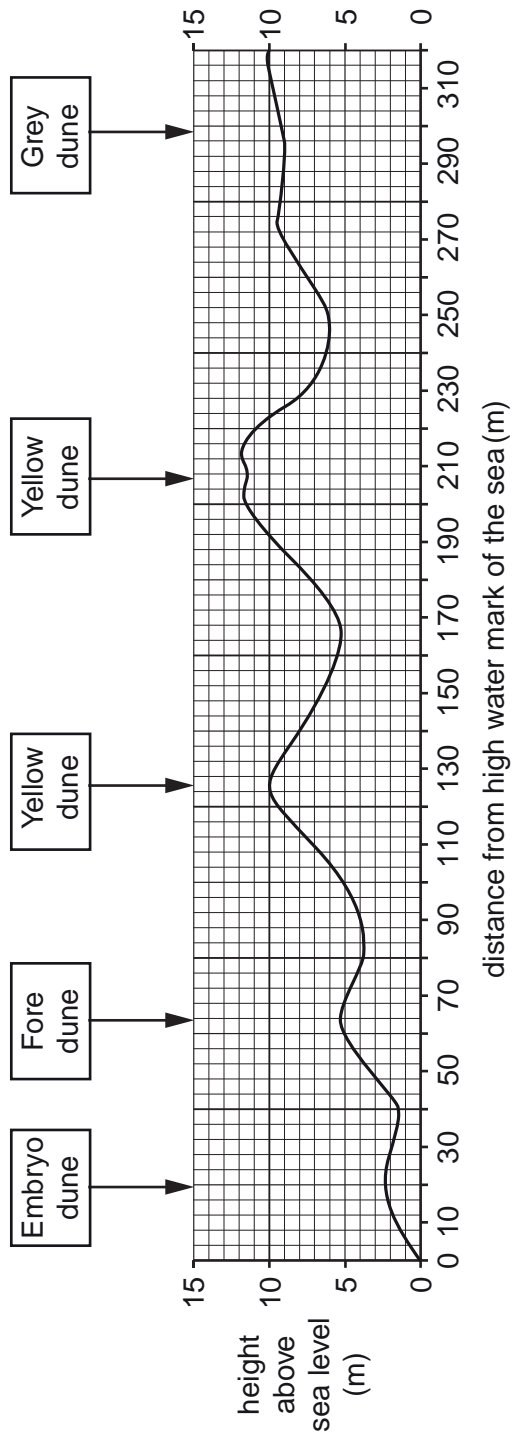

Table 1 for Question 1

Students' fieldwork results



| Site along transect | Distance from high water mark of sea (m) | Amount of vegetation cover (%) | Main type of vegetation |
|---------------------|--|--------------------------------|-------------------------|
| 1 | 10 | 20 | Sea couch grass |
| 2 | 30 | 30 | Sea lyme grass |
| 3 | 50 | 25 | Marram grass |
| 4 | 70 | 40 | Marram grass |
| 5 | 90 | 50 | Rosette plants |
| 6 | 110 | 55 | Marram grass |
| 7 | 130 | 50 | Marram grass |
| 8 | 150 | 60 | Marram grass |
| 9 | 170 | 55 | Rosette plants |
| 10 | 190 | 60 | Marram grass |
| 11 | 210 | 75 | Brambles |
| 12 | 230 | 60 | Marsh plants |
| 13 | 250 | 70 | Marsh plants |
| 14 | 270 | 90 | Gorse |
| 15 | 290 | 95 | Heather |
| 16 | 310 | 85 | Heather |

Fig. 5 for Question 2

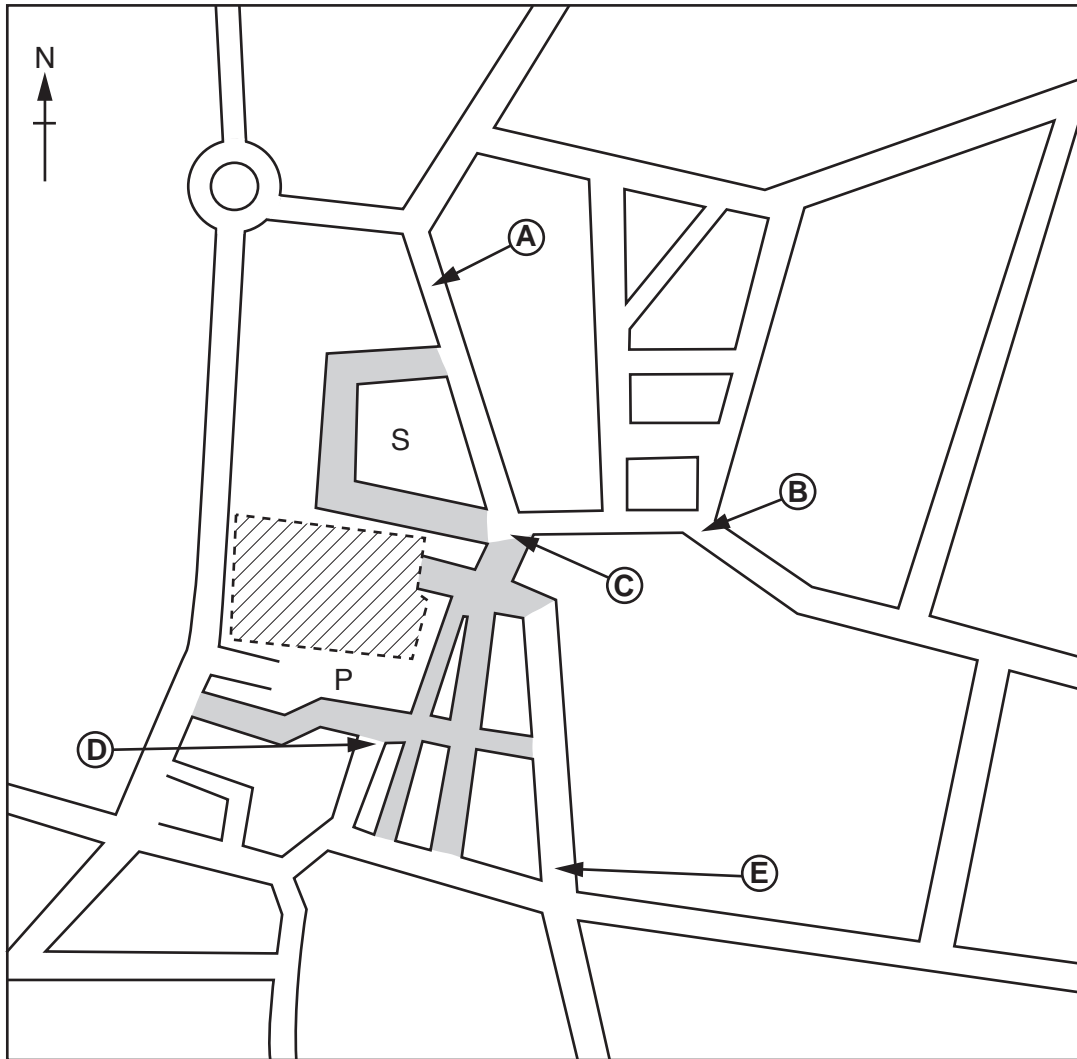
Location of the new shop in the CBD



Key

-  new shop
- P** shop car park
- S** indoor shopping area
-  restricted access for vehicles
-  location of survey points

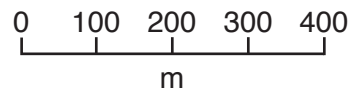

Table 2 for Question 2

Results of the questionnaire

| Statement | Agree strongly | Agree | Disagree | Disagree strongly |
|---|----------------|-----------|-----------|-------------------|
| The shop has brought a larger variety of goods and services to the town centre. | 38 | 26 | 33 | 3 |
| The shop attracts people to come to the town centre more often. | 31 | 40 | 20 | 9 |
| The shop has provided more jobs in the town centre. | 57 | 37 | 3 | 3 |
| The shop has meant increased competition for other shops in the town centre. | 24 | 25 | 37 | 14 |

Fig. 9 for Question 2

Environmental quality recording sheet

| Environmental quality survey | | | | | | | |
|--|---|---|---|---|---|---|--|
| Location: Area A/B/C/D/E (circle the area) | | | | | | | |
| Feature | Negative description | 1 | 2 | 3 | 4 | 5 | Positive description |
| Building layout and design | Poorly laid out, unattractive appearance | | | | | | Well laid out, attractive appearance |
| Building care and condition | Poorly maintained | | | | | | Well maintained |
| Pavements | No pavement or poorly maintained | | | | | | Well maintained and safe to walk on |
| Traffic | Lots of traffic causing congestion and queues | | | | | | Very little traffic moving freely or pedestrianised |
| Public open space | None, unattractive natural environment | | | | | | Plenty of public open space and attractive natural environment |
| Noise | Very noisy from different sources | | | | | | Quiet and causes no inconvenience |
| General appearance | Widespread litter, graffiti, damage | | | | | | No litter, graffiti, damage |

7

Table 3 for Question 2

Results of survey

| Feature | Survey point | | | | |
|-----------------------------|--------------|----------|----------|----------|----------|
| | A | B | C | D | E |
| Building layout and design | 3 | 2 | 4 | 5 | 3 |
| Building care and condition | 4 | 2 | 4 | 5 | 3 |
| Pavements | 4 | 2 | 4 | 4 | 3 |
| Traffic | 3 | 3 | 5 | 4 | 2 |
| Public open space | 3 | 1 | 4 | 5 | 2 |
| Noise | 2 | 2 | 3 | 3 | 2 |
| General appearance | 3 | 2 | 3 | 4 | 2 |
| Total score | 22 | 14 | 27 | 30 | 17 |

BLANK PAGE

Permission to reproduce items where third-party owned material protected by copyright is included has been sought and cleared where possible. Every reasonable effort has been made by the publisher (UCLES) to trace copyright holders, but if any items requiring clearance have unwittingly been included, the publisher will be pleased to make amends at the earliest possible opportunity.

To avoid the issue of disclosure of answer-related information to candidates, all copyright acknowledgements are reproduced online in the Cambridge International Examinations Copyright Acknowledgements Booklet. This is produced for each series of examinations and is freely available to download at www.cie.org.uk after the live examination series.

Cambridge International Examinations is part of the Cambridge Assessment Group. Cambridge Assessment is the brand name of University of Cambridge Local Examinations Syndicate (UCLES), which is itself a department of the University of Cambridge.